

Reliable®

Model E 4" (100 mm), 6" (150 mm) and 8" (200 mm) Alarm Check Valves with Model E3 Trim

Features

1. Made expressly for all wet-pipe sprinkler systems.
2. Clappers' grooved seat design insures positive water flow alarm operation.
3. Precision retard chamber prevents false alarms under variable pressure conditions.
4. External by-pass aids prevention of false alarms under all supply pressure conditions.
5. Installation in either vertical or horizontal positions.
6. Three connection styles available:
 - ANSI flanged inlet and outlet
 - ANSI flanged inlet and grooved outlet
 - Metric flanged inlet and outlet
7. Pressure trim styles available:
 - Individual part trim
 - Pre-assembled trim
 - Factory trimmed valve
8. Pressure Relief Trim approved by Factory Mutual Corporation. (FM)

Approvals & Listings:

1. Listed by Underwriters Laboratories and certified by UL for Canada (cULus)
2. Approved by Factory Mutual Research Corp. (FM)
3. LPC (UK)
4. NYC BS & A No. 587-75-SA.
5. Scientific Services Laboratory (SSL, Australia) Alarm Check Valves; metric gauge 100mm, 150mm, 200mm.



The Reliable Model E Alarm Check Valve acts as a Water Flow Alarm Device in wet pipe sprinkler systems. The design allows for installation under both variable and constant supply pressure conditions. When water flows in the sprinkler system due to the operation of one or more Automatic Fire Sprinklers the Alarm Valve opens, allowing continuous flow of water into the system and a transmission of an alarm, both electrically and mechanically.



Operation Variable Pressure

The Reliable Model E Alarm Check Valve in its closed and open positions is shown in Fig. 1 and Fig. 2. The closed position is maintained as long as the water pressure in the sprinkler system piping above the Alarm Valve is greater than, or equal to, the supply pressure. A flow of water in the system piping, resulting from the discharge through one or more fused Automatic Sprinkler(s), causes the Clapper to rise off its Grooved Seat and permits water from the supply to enter the system for distribution on the fire.

Virtually all sprinkler systems piping contain confined air. If a water hammer or pressure surge occurs in the supply line, the increased pressure will compress the confined air and cause the Alarm Valve Clapper to lift intermittently which may result in false alarms. The Model E Alarm Check Valve prevents false alarms under these conditions using two features:

- a. The By-Pass connection with Check Valve (Figure 3 & 4) allows pressure surges from the supply to by-pass the Alarm Valve Clapper. An excess system pressure is thus created which steadies the Clapper. Should a heavy surge unseat the Clapper and permit water to flow into the alarm line, the Retard Chamber then comes into action.
- b. Drain Orifice Restriction from / to the Retard Chamber allows intermittent flows to be drained before the Chamber fills and activates the Alarms.

Constant Pressure

The operation of the Model E Alarm Check Valve in installations where the water pressure is constant, is the same as described above, with this exception: The Retard Chamber is not required and water passing through the Groove in the Alarm Check Valve Seat flows directly to and activates the Mechanical and Electrical Alarms.

Note: 1 bar=100 kPa

Model E Alarm Valve

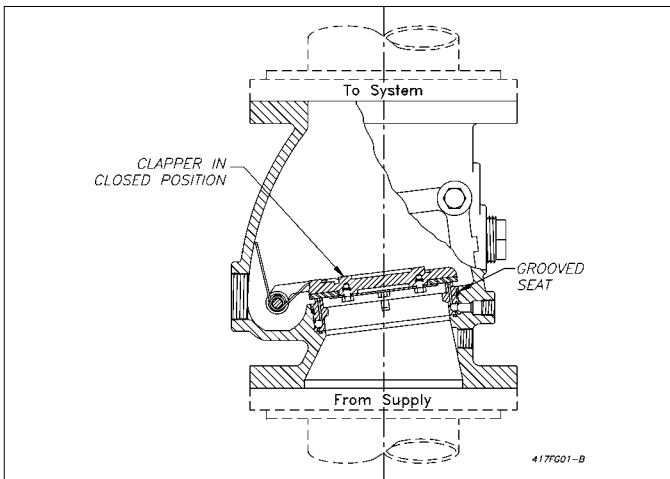

Fig. 1

Valve Description

1. Rated working pressure 175 psi (12,3 bar).
2. Factory hydrostatic test pressure 350 psi (24,6 bar).
3. End and trim connections—Three valve connection styles are available.
 - a. US Standard Flanged Inlet and Outlet
 - Flanges mate with ANSI B 16.1 (125 lb.) Flange

U.S. Flange Dimensions In Inches (mm)					
Valve Size	Bolt Circle Dia.	Bolt Hole Dia.	Flange Outside Dia.	Flange Thickness	No. Bolts
4 (100mm)	7½	¾	9	15/16	8
6 (150mm)	9½	7/8	11	1	8
8 (200mm)	11¾	7/8	13½	1 1/8	8

- Threaded openings per ANSI B 2.1.
- Reliable's standard trim sets are compatible with US Flanged Valves.
- Color—Black
- b. US Standard Flanged Inlet and Grooved Outlet
 - Inlet flange mates with ANSI B 16.1 (125 lb.) Flange.
 - Outlet groove per ANSI/AWWA C606

U.S. Groove Dimensions In Inches (mm)				
Valve Size	Outlet Dia.	Groove Dia.	Groove Width	Outlet Face To Groove
4 (100mm)	4.500 (114)	4.334 (110)	3/8 (9.5)	5/8 (16)
6 (150mm)	6.625 (168)	6.455 (168)	3/8 (9.5)	5/8 (16)
8 (200mm)	8.625 (219)	8.441 (214)	7/16 (11.11)	3/4 (19)

- Threaded openings per ANSI B 2.1
- Reliable's standard trim sets are compatible with US Flanged and Grooved Valves.
- Color—Black
- c. Metric Flanged Inlet and Outlet
 - 100mm & 150mm valve plain face flanges mate with DIN2501, NF-E-29-282, ISO 2084 NP10 and NP16 and BS4504 NP10 and NP16.
 - 200mm valve raised face flanges mate with DIN 2501, ISO 2084 NP16 and BS4504 NP16.

Metric Flange Dimensions in Millimeters							
Valve Size	Bolt Circle Dia.	Bolt Hole Dia.	Raised Dia.	Face Ht.	Flange Outside Dia.	Flange Thickness	No. Bolts
100mm	180	18.3	—	—	229	23.8	8
150mm	241	22.2	—	—	279	25.4	8
200mm	295	22.2	268	3	343	28.6	12

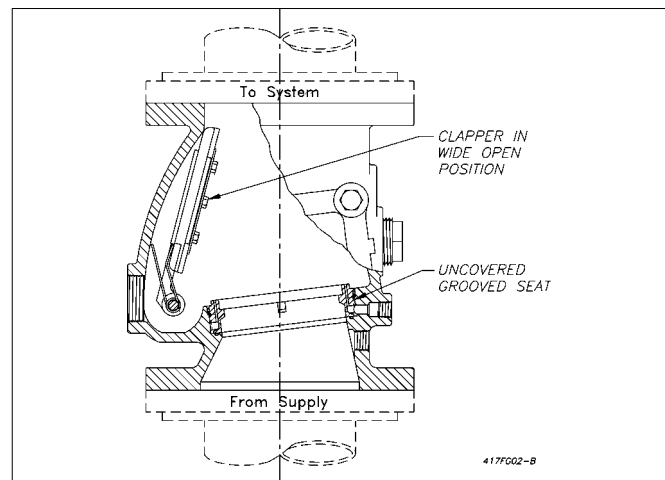

Fig. 2

- Threaded openings per BS21-1957.
- Reliable's standard trim sets may be used with Metric Valves providing trim is assembled carefully and extra thread sealant is applied to connections between valves and trim.
- Color— Blue

4. Face to Face Dimension

- For 4 (100 mm) Model —11¾ (299 mm)
- For 6 (150 mm) Model —13½ (343 mm)
- For 8 (200 mm) Model —14 ½ (368 mm)

5. Shipping Weight

	Flanged Inlet and Outlet	Flanged Inlet and Grooved Outlet
4 (100 mm)	80 lb. (36.3 kg)	70 lb. (31.8 kg)
6 (150 mm)	116 lb. (52.6 kg)	102 lb. (46.3 kg)
8 (200 mm)	155 lb. (70.3 kg)	143 lb. (64.9 kg)

6. Friction Loss—Expressed in Equivalent Length of Pipe, Based on Hazen & Williams formula with C = 120.

	Equiv Length
4 (100 mm)	17 (5.18 m)
6 (150 mm)	27 (8.23 m)
8 (200 mm)	29 (8.84 m)

7. Installation position—All sizes may be installed either vertically or horizontally.

Model E3 Trim Description

The E3 trim sets for the Reliable Model E Alarm Valve (Figs. 3 & 4) are arranged for rapid, easy and compact attachment, and serve as connection points to Reliable alarm and other devices. They also act as a means for testing the system to operate. The Model E alarm valves are available in two trims and may be installed in the vertical or horizontal position in the main supply to the wet pipe system:

- **Constant Pressure, Closed Drain** - Retard Chamber is not required. The Model E3 trim comes as a constant pressure trim. This trim set is used where water supply pressure does not vary, such as a gravity tank, mechanical sprinkler alarm line automatically drains to the 2 (50mm) main drain line.
- **Variable Pressure with Closed Retard Chamber Drain**—Retard Chamber is required. This trim is used where water supply pressures vary. An open Drip Cup is provided to drain the Retard Chamber and the Mechanical Sprinkler Alarm line. This drain connection should be piped separately from the 2" main drain.
- **Variable Pressure with Open Retard Chamber Drain**—Retard chamber is required. Optional Drain Line Kit required (see Figs. 3 & 4). This trim set is used where water supply pressures vary. An open drip cup is provided to drain the retard chamber and the mechanical sprinkler alarm line. This drain connection should be piped separately from the 2" main drain.

Note:

- The trim set permits both vertical (Fig. 3) and horizontal (Fig. 4) installations.
- A Test_{AN}Drain valve segment is optional, to be purchased separately, as a replacement to the Drain valve (see optional Kit in Figs. 3 & 4).
- All trim sets can be fitted with an optional Pressure Relief Trim Kit (see optional kit in Figs. 3 & 4) to relieve pressures above 175 psi in the sprinkler system, as required by NFPA 13, 3-1.2.

- **Pressure Relief Trim Kit**—Required with a wet pipe system when a rise in ambient temperature can cause system pressure to exceed 175 psi (12 bar) or with gridded systems.

Pressure relief trim is not intended for use in relieving water hammer or fire pump surges. It must be installed and maintained in compliance with NFPA 13, local codes and the authority having jurisdiction.

Trim Kits are available, galvanized or ungalvanized, (ungalvanized is standard) in three trim styles:

- Individual part trim
- Pre-assembled trim
- Factory trimmed valve

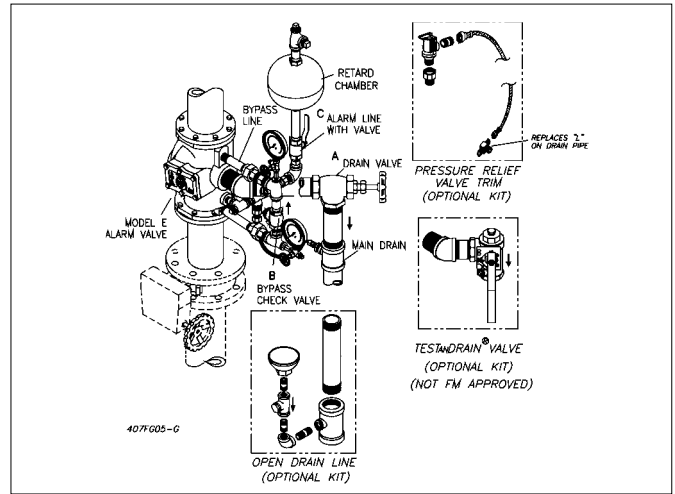

Fig. 3

Alarm valves are listed and approved by Underwriters Laboratories, Inc. and Factory Mutual Research Corp. only when used with the valve manufacturer's trim sets.

Ordering Information— Specify:

- Valve Size — 4 (100mm), 6 (150mm) or 8 (200mm). When size is specified in mm, a metric valve per 3.c will be supplied.
- Inlet and Outlet Connection—Either Flanged/Flanged or Flanged/Grooved.
- Type of Trim—Constant Pressure or Variable Pressure/Open Drain or Variable Pressure/Closed Drain.
- Style of Trim—Individual Part Trim or Pre-Assembled
- Additional Equipment—Retard Chamber, Mechanical Sprinkler Alarm, Pressure Relief Trim Kit, and Pressure Alarm Switch must be separately ordered.

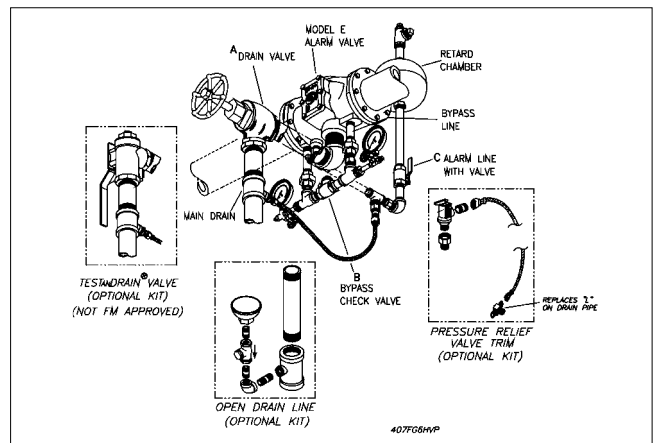
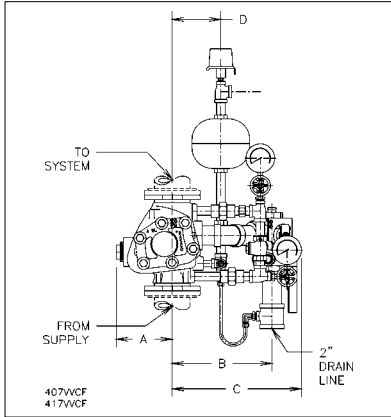

Figure 4

**Model E3 Trim Illustrations Vertical & Horizontal
Installation Measurement in Inches (mm)**

Valve	A	B	C	D	E	F	G	H	I	J	K	L	M
4 (100)	7 (178)	10½ (267)	16½ (419)	6 (152)	16¾ (426)	15 (381)	3½ (89)	5¾ (146)	12 (305)	4½ (114)	6½ (165)	10 (254)	8¼ (210)
6 (150) (165)	7⅝ (194)	11½ (292)	17½ (445)	7 (178)	15¼ (387)	16½ (419)	4¼ (108)	7 (178)	12 (305)	4½ (114)	6½ (165)	10 (254)	6¾ (172)
8 (200)	7⅝ (194)	11½ (292)	17½ (445)	7 (178)	15¼ (387)	16½ (419)	4¼ (108)	7 (178)	12 (305)	4½ (114)	6½ (165)	10 (254)	6¾ (172)

Vertical Trim, Variable Pressure -
Front Elevation



Horizontal Trim, Variable Pressure -
Front Elevation

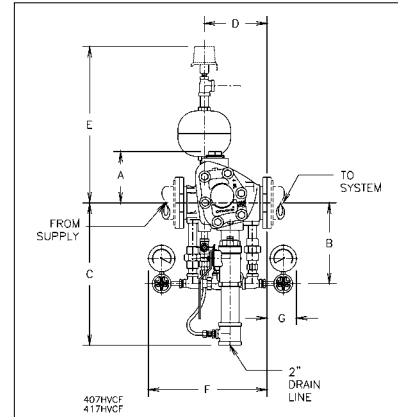

Vertical Trim, Variable Pressure - Top View

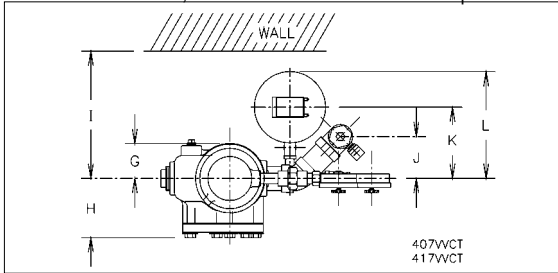

Horizontal Trim, Variable Pressure - Top View

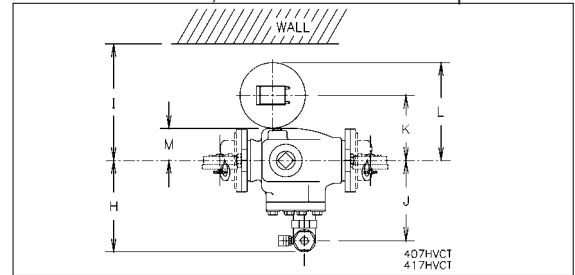

Vertical Trim, Constant Pressure -
Front Elevation

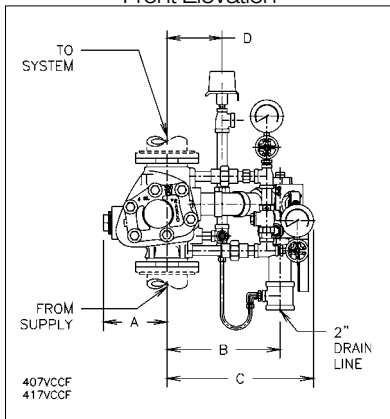

Horizontal Trim, Constant Pressure -
Front Elevation

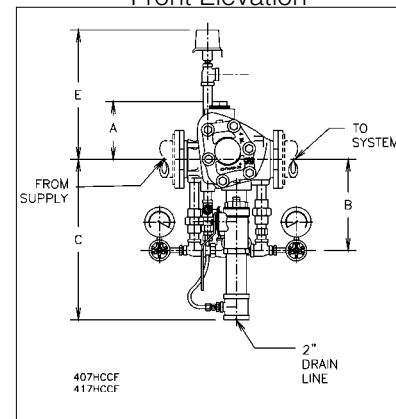

The equipment presented in this bulletin is to be installed in accordance with the latest pertinent Standards of the National Fire Protection Association, Factory Mutual Research Corporation, or other similar organizations and also with the provisions of governmental codes or ordinances, whenever applicable.

Products manufactured and distributed by RELIABLE have been protecting life and property for over 80 years, and are installed and serviced by the most highly qualified and reputable sprinkler contractors located throughout the United States, Canada and foreign countries.

Manufactured by



The Reliable Automatic Sprinkler Co., Inc.

(800) 431-1588

(800) 848-6051

(914) 668-3470

www.reliablesprinkler.com

Sales Offices

Sales Fax

Corporate Offices

Internet Address



Revision lines indicate updated or new data.

EG. Printed in U.S.A. 3/02 P/N 999970050