



Model F1FR Model F1FR Recessed Quick Response Sprinklers

Model F1FR Sprinkler Types

- Standard Upright
- Standard Pendent
- Conventional
- Vertical Sidewall
- Horizontal Sidewall
 - HSW 1 Deflector

Model F1FR Recessed Sprinkler Types

- Recessed Pendent
- Recessed Horizontal Sidewall
 - HSW 1 Deflector

Product Description

Reliable Models F1FR and F1FR Recessed Sprinklers are quick response sprinklers which combine the durability of a standard sprinkler with the attractive low profile of a decorative sprinkler.

The Models F1FR and F1FR Recessed automatic sprinklers utilize a 3.0 mm frangible glass bulb. These sprinklers have demonstrated response times in laboratory tests which are five to ten times faster than standard response sprinklers. This quick response enables the Model F1FR and F1FR Recessed sprinklers to apply water to a fire much faster than standard sprinklers of the same temperature rating.

The glass bulb consists of an accurately controlled amount of special fluid hermetically sealed inside a precisely manufactured glass capsule. This glass bulb is specially constructed to provide fast thermal response. The balance of parts are made of brass, copper and beryllium nickel.

At normal temperatures, the glass bulb contains the fluid in both the liquid and vapor phases. The vapor phase can be seen as a small bubble. As heat is applied, the liquid expands, forcing the bubble smaller and smaller as the liquid pressure increases. Continued heating forces the liquid to push out against the bulb, causing the glass to shatter, opening the waterway and allowing the deflector to distribute the discharging water.

The temperature rating of the sprinkler is identified by the color of the glass bulb.



Upright



Pendent



Vertical Sidewall



Conventional

Horizontal Sidewall
HSW 1 Deflector

Recessed Pendent

Application

Quick response sprinklers are used in fixed fire protection systems: Wet, Dry, Deluge or Preaction. Care must be exercised that the orifice size, temperature rating, deflector style and sprinkler type are in accordance with the latest published standards of the National Fire Protection Association or the approving Authority Having Jurisdiction. Quick response sprinklers are intended for installation as specified in NFPA 13. Quick response sprinklers and standard response sprinklers should not be intermixed.

Model F1FR Quick Response Upright, Pendent & Conventional Sprinklers

Installation Wrench: Model D Sprinkler Wrench

Installation Data:

Sprinkler Type Standard-Upright (SSU) and Pendent (SSP) Deflectors Marked to Indicate Position	"K" Factor		Sprinkler Height	Approval Organization	Sprinkler Identification Number (SIN)	
	US	Metric			SSU	SSP
1/2" (15mm) Standard Orifice with 1/2" NPT (R1/2) Thread	5.62	81.0	2.2" (56mm)	1,2,3,4,5,6,7	R3625	R3615
17/32" (20mm) Large Orifice with 3/4" NPT (R3/4) Thread	8.0	115.3	2.3" (58mm)	1,2,3,4,7,8	R3622	R3612
7/16" (11mm) Small Orifice with 1/2" NPT (R1/2) Thread ⁽¹⁾	4.24	61.0	2.54" (65mm)	1,2,8	R3623	R3613
3/8" (10mm) Small Orifice with 1/2" NPT (R1/2) Thread ⁽¹⁾	2.82	40.6	2.54" (65mm)	1,2,8	R3621	R3611
10mm Orifice XLH with R3/8" Thread	4.10	59.1	56.1mm	4,6,7	R3624	R3614
Conventional-Install in Upright or Pendent Position						
10mm Orifice XLH with R3/8" Thread	4.10	59.1	56.1mm	—		R3674
15mm Standard Orifice with 1/2" NPT (R1/2) Thread	5.6	81.0	56.1mm	4,6,7		R3675
20mm Large Orifice with 3/4" NPT (R3/4) Thread	8.0	115.3	58.4mm	4,7		R3672

⁽¹⁾ Identified by a pintle extending beyond the deflector.



Upright



Pendent



Upright⁽¹⁾

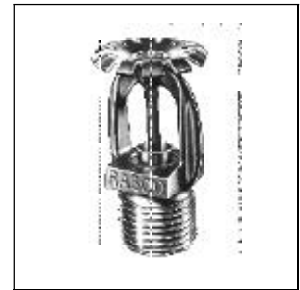

Conventional

Model F1FR Quick Response Recessed Pendent Sprinkler

Installation Wrench: Model RC1 Sprinkler Wrench

Installation Data:

Nominal Orifice	Thread Size	"K" Factor		Sprinkler Height	Approval ⁽²⁾ Organizations	Sprinkler Identification Number (SIN)
		US	Metric			
1/2" (15mm)	1/2" NPT (R1/2)	5.62	81.0	2.2" (56mm)	1,2,3,4,5,7,8	R3615
17/32" (20mm)	3/4" NPT (R3/4)	8.0	115.3	2.3" (58mm)	1,2,3	R3612
7/16" ⁽¹⁾ (11mm)	1/2" NPT (R1/2)	4.24	61.0	2.54" (65mm)	1,2,8	R3613
3/8" ⁽¹⁾ (10mm)	1/2" NPT (R1/2)	2.82	40.6	2.54" (65mm)	1,2,8	R3611
10mm	R3/8"	4.10	59.1	56.1mm	4,7	R3614

⁽¹⁾ Identified by a pintle extending beyond the deflector.

⁽²⁾ Refer to es catch eon data ta ble for ap provals and di men sions.

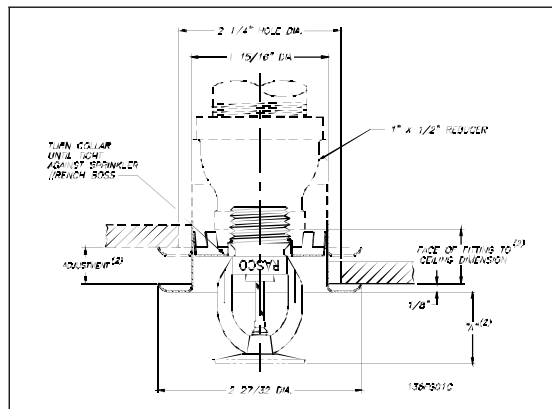

Model F1FR Quick Response Vertical Sidewall Sprinkler

Installation Wrench: Model D Sprinkler Wrench

Installation Position: Upright or Pendent

Approval Type: Light Hazard Occupancy

Installation Data:

Nominal Orifice	Thread Size	"K" Factor		Sprinkler Height	Approval Organizations	Sprinkler Identification Number (SIN)
		US	Metric			
1/2"	1/2" NPT (R1/2)	5.62	81.0	2.2" (56mm)	1, 2, 3, 6, 8	R3685
15mm	1/2" NPT (R1/2)	5.62	81.0	2.2" (56mm)	4 ⁽¹⁾	

⁽¹⁾ LPC Approval is Pendent only.

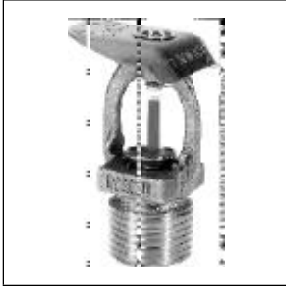

Vertical Sidewall

Orientation	Deflector to Ceiling Dimension (Min. - Max.)
Upright	4" - 12" (102mm - 305mm)
Pendent	6" - 12" (152mm - 305mm)

Model F1FR Quick Response Horizontal Sidewall Sprinkler

Deflector: HSW 1

Installation Wrench: Model D Sprinkler Wrench

Installation Data:

Nominal Orifice	Thread Size	"K" Factor		Sprinkler Length	Approval Organizations and Type of Approval		Sprinkler Identification Number (SIN)
		US	Metric		Light Hazard	Ordinary Hazard	
1/2" (15mm)	1/2" NPT (R1/2)	5.62	81.0	2.63" (67mm)	1,2,3,5,8	1,2,5,8	R3635

NOTE: UL and ULC Listing permits use with F1 or F2 recessed escutcheon.



Horizontal Sidewall

Installation

Quick response sprinklers are intended for installation as specified in NFPA 13. Quick response sprinklers and standard response sprinklers should not be intermixed.

The Model F1FR Recessed Quick Response Sprinklers are to be installed as shown. The Model F1 or F2 Escutcheons illustrated are the only recessed escutcheons to be used with the Model F1FR Sprinklers. The use of any other recessed escutcheon will void all approvals and negate all warranties.

When installing Model F1FR Sprinklers, use the Model D Sprinkler Wrench. When installing Model F1FR Recessed Sidewall Sprinklers, use the Model GFR1 Sprinkler Wrench. Use the Model RC1 Wrench for installing F1FR Recessed Pendent Sprinklers. Any other type of wrench may damage these sprinklers.

Approval Organizations

1. Underwriters Laboratories, Inc.
2. Underwriters' Laboratories of Canada
3. Factory Mutual Research Corporation
4. Loss Prevention Council
5. NYC BS&A No. 587-75-SA
6. Meets MIL-S-901C and MIL-STD 167-1
7. Verband der Schadenversicherer
8. NYC MEA 258-93-E

ULI Listing Category

Sprinklers, Automatic & Open Quick Response Sprinkler

ULI Guide Number

VNIV

Temperature Ratings

Classification	Sprinkler Temperature		Max. Ambient Temp.	Bulb Color
	°C	°F		
Ordinary	57	135	100°F (38°C)	Orange
Ordinary	68	155	100°F (38°C)	Red
Intermediate	79	175	150°F (66°C)	Yellow
Intermediate	93	200	150°F (66°C)	Green
High ⁽¹⁾	141	286	225°F (107°C)	Blue

⁽¹⁾ Not available for recessed sprinklers.

Escutcheon Data

Escutcheon Model	Approvals	Adjustment	"A" Dimension	Face of Fitting to Ceiling or Wall Dimension
F1	1,2,4	$\frac{3}{4}$ " (19mm)	$\frac{3}{4}$ " (19mm)	$\frac{3}{16}$ " - $\frac{15}{16}$ " (5mm - 24mm)
F2	1,2,3,4,5,7,8	$\frac{1}{2}$ " (13mm)	1" (25mm)	$\frac{3}{16}$ " - $\frac{1}{16}$ " (5mm - 24mm)

Maintenance

The Models F1FR and F1FR Recessed Sprinklers should be inspected quarterly and the sprinkler system maintained in accordance with NFPA 25. Do not clean sprinklers with soap and water, ammonia or any other cleaning fluids. Remove dust by using a soft brush or gentle vacuuming. Remove any sprinkler which has been painted (other than factory applied) or damaged in any way. A stock of spare sprinklers should be maintained to allow quick replacement of damaged or operated sprinklers. Prior to installation, sprinklers should be maintained in the original cartons and packaging until used to minimize the potential for damage to sprinklers that would cause improper operation or non-operation.

Sprinkler Types

Standard Upright
Standard Pendent
Conventional
Sidewall (Vertical, Horizontal HSW1)
Recessed Pendent
Recessed Horizontal Sidewall HSW1

Finishes ^{(1) (2)}

Standard Finishes	
Sprinkler	Escutcheon
Bronze	Brass
Chrome Plated	Chrome Plated
White Polyester Coated	White Painted
Special Application Finishes	
Sprinkler	Escutcheon
Bright Brass	Bright Brass
Black Plated	Black Plated
Black Paint	Black Paint
Off White	Off White
Satin Chrome	Satin Chrome

⁽¹⁾ Other finishes and colors are available on special order. Consult the factory for details.

⁽²⁾ FM Approval is limited to bronze and brass, chrome or black plated finishes only.

Ordering Information

Specify:

1. Sprinkler Model
2. Sprinkler Type
3. Orifice Size
4. Deflector Type
5. Temperature Rating
6. Sprinkler Finish
7. Escutcheon Type
8. Escutcheon Finish (where applicable)

Note: When Model F1FR Recessed sprinklers are ordered, the sprinklers and escutcheons are packaged separately.

The equipment presented in this bulletin is to be installed in accordance with the latest pertinent Standards of the National Fire Protection Association, Factory Mutual Research Corporation, or other similar organizations and also with the provisions of governmental codes or ordinances when ever applicable.

Products manufactured and distributed by Reliable have been protecting life and property for over 80 years, and are installed and serviced by the most highly qualified and reputable sprinkler contractors located throughout the United States, Canada and foreign countries.

Manufactured by



The Reliable Automatic Sprinkler Co., Inc.

(800)431-1588
(800)848-6051
(914)668-3470
www.reliablesprinkler.com

Sales Offices
Sales Fax
Corporate Offices
Internet Address



Revision lines indicate updated or new data

EG. Printed in U.S.A. 12/00

P/N9999970027