



SHORT CIRCUIT ISOLATOR: CHQ-SCI-S

Features

Short circuit isolator for signal transmission line

- Position at any point on S-SC line
- Quick and reliable detection of short circuit to prevent total system failure
- LED indication when a short is detected

The CHQ-SCI-S is to be installed in conjunction with CHQ-SCI-E (Short circuit isolator for signal line terminal) or equivalent signal terminal isolator or similar function

Operation

The CHQ-SCI-S can be position anywhere between loop devices on the S-SC signal transmission line. Upon detection of a short circuit on the loop, the short circuit isolator will switch to break the loop wiring. Two* units will operate either side of the short circuit to isolate that part of the loop wiring, any devices on that part of the loop will become inoperative. The fire alarm control panel will communicate with the remaining devices from both ends of the loop. An indication LED will illuminate when the isolator operates.

*The minimum requirement for a short circuit isolation is to have a CHQ-SCI-E (or equivalent with similar function) on the start/end line terminal and a CHQ-SCI-S position anywhere between loop devices.

Principle of Operation

(CHQ-SCI-S for S-SC signal transmission line)

When power is supplied to terminal S1, SC1 (or S2, SC2) under normal condition without detecting any short on S2, SC2 (or S1, SC1) terminals, the isolator unit SCI-S-1 initiate itself by switching on its internal FET. If a short is detected on S2 during initialisation, the internal FET of isolator SCI-S-1 remains open which isolates the point of short during system initialisation. Detection of line short during system operation is carried out by line terminal isolator CHQ-SCI-E.

FIRE & SAFETY PRODUCTS (A/ASIA) PTY. LTD.

A.C.N. 007 954 832 (Inc. in South Australia)



85 ORSMOND STREET
PO BOX 131
HINDMARSH SA 5007
PHONE: (08) 8346 5061
FAX: (08) 8340 0099

A member of the WILLIAMS GROUP OF COMPANIES

SPECIALIST DISTRIBUTORS OF FIRE PROTECTION PRODUCTS



Quality
Endorsed
Company
AS N2 ISO 9002
Lic No. QEC 1411



Refer to system structure shown in figure 1.

1. Before system initialisation (power off), all internal FET switches on SCI-S are opened.
2. During initialisation (power on) via (Sout, SCout), the internal FET of each SCI-S will be switched on sequentially when power supply is applied across the S-SC transmission line.
3. Each FET circuit are energized as follows: SW1 ~ SCI-S1 ~ SCI-S2 ~ SCI-S3 ~ and so on. SW2 and SW3 remain open when no short is detected during system power up.
4. If a line short occurs at point 'A' during system startup, detection circuit - 1 identifies the short and SW1 remains open.
5. Detection circuit - 2 recognises the short circuit and if no line short occurs at (Sin, SCin), the line terminal isolator (CHQ-SCI-E) switches over and energizes SW2 and SW3. A trouble signal is relayed to the fire alarm control panel by the CHQ-SCI-E.
6. Upon switching over the system re-initialise itself via (Sin, SCin) and energize SCI-S3 and SCI-S2 while isolating short circuit point 'A' leaving SCI-S1 open.
7. If a short or open circuit occurs at point 'B' instead during system startup, the terminal isolator (CHQ-SCI-E) continues with the initialisation, energizing each FET via (Sout, SCout).
8. In the event of a short circuit at point B, the initialisation stops at SCI-S1 leaving SCI-S2 and SCI-S3 open. On the other hand if point B has an open circuit instead, then the initialisation process will stop at SCI-S2 leaving SCI-S3 open.

9. In both instances, the detection circuit 2 on the CHQ-SCI-E with detect the trouble on the S-SC line and immediately switches on SW2 and SW3 thus enabling the loop to be completed via Sin, SCin.
10. A line short at point B will leave SCI-S2 and SCI-S3 open thus isolating the line between these 2 isolator while a line open at point B will enable all the SCi-S's to be energize and power will be supplied to the line devices via the 2 terminals (Scout, SCout) and (Sin, SCin).
11. When a line trouble (open or short circuit) occurs during operating condition, the transmission line will immediately be shutdown and power up again to re-initialise the loop. The re-initialisation process will repeat itself as explained in step 2-9.

Applications

The CHQ-SCI-S short circuit isolator unit is used where systems requirement state the loop should be protected for short circuit. This unit is designed to fit between loop devices to protect the loss of too many devices should a short circuit occurs on the transmission loop. By installing a number of units the overall integrity of the loop can be maintained during short circuit condition.

It is recommended that no more than 32 CHQ-SCI-S's are installed on the same detection loop, and no more than 20 devices are installed between two CHQ-SCI-S's.

Specifications (at 25°C)

		CHQ-SCI-S	CHQ-SCI-E
Operating Voltage		17V -41V	
Current Consumption	Quiescent	130µA (Typ)	1mA (Typ)
	In Short Circuit Condition	7.6mA (Type)	22mA (Type)
Maximum Current (Short Circuit Condition)		500mA	
Resistance		0.3Ω	
Isolating Resistance		80KΩ	
Short Circuit Threshold Level		<500Ω	
Operating Ambient Temperature Range		-10°C ~ +50°C	
Storage Temperature Range (Under Humidity 80%)		-30°C ~ +60°C (<80% RH at 60°C)	
Allowable Ambient Humidity (at 40°C)		95% RH Non-Condensing	
Dimensions		93mm x 72mm	
Weight		Approximately 40g (P.C.B. Only)	Approximately 50g (P.C.B. Only)

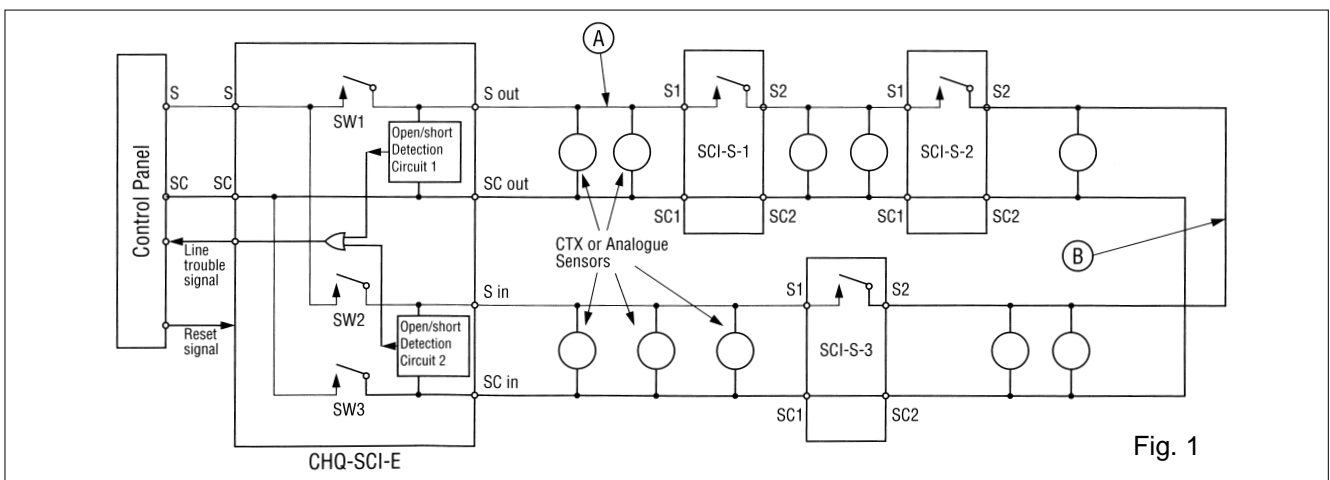

Fig. 1

In line with a continuous programme of product development, the Manufacturer reserves the right to modify or update specifications without notice. It should be noted that the exact specification may vary depending on the configuration of the designed system. The information herein is to assist in determining whether this product is suitable for a given application. This information does not purport to cover all details or variations in the equipment described, nor does it provide for every possible contingency to be met in connection with installation, operation and maintenance. We request that customers inspect and test our products before use and satisfy themselves as to contents and suitability. NOTHING HEREIN SHALL CONSTITUTE A WARRANTY, EXPRESSED OR IMPLIED, INCLUDING ANY WARRANTY OF MERCHANTABILITY OR FITNESS FOR A PARTICULAR PURPOSE.